

## SERIES 136

## DIGITAL INSIDE POINT CALIPER

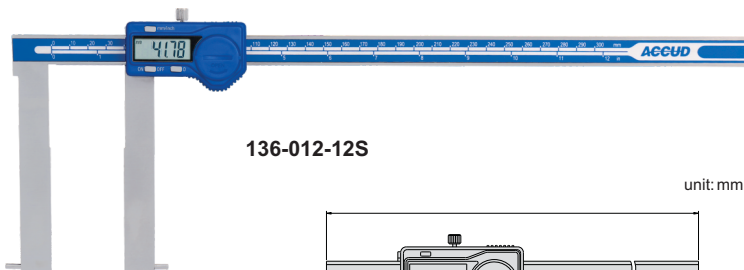

136-012-12S

unit: mm

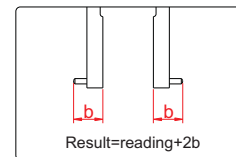
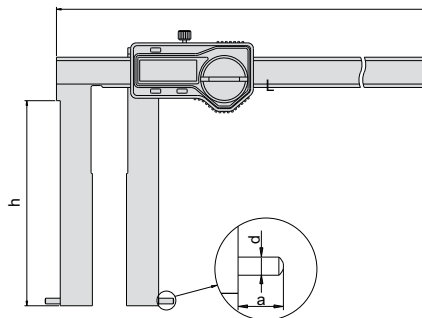

- ◆ Measure the grooves
- ◆ Resolution: 0.01mm/0.0005"
- ◆ Automatic power on/off
- ◆ Buttons: on/off, zero, mm/inch
- ◆ Data output
- ◆ Made of stainless steel

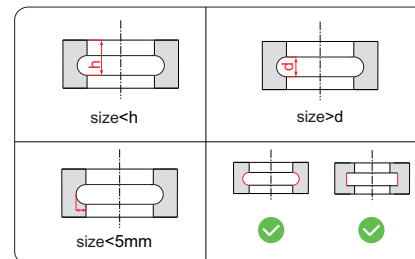
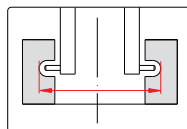

Code	Range	Accuracy	a	d	h	L
136-012-12S	50-300mm	±0.06mm	8	3	90	410
136-012-13S	50-300mm	±0.06mm	8	3	110	410