

DIGITAL CALIPER WITH INTERCHANGEABLE POINTS

SERIES 149

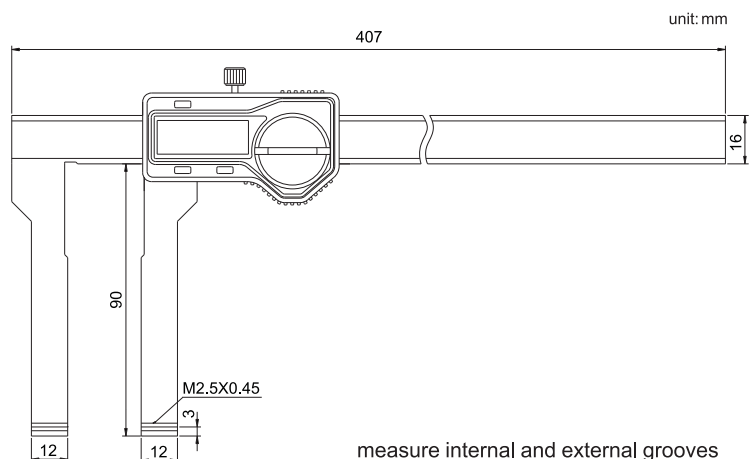

measure internal and external grooves

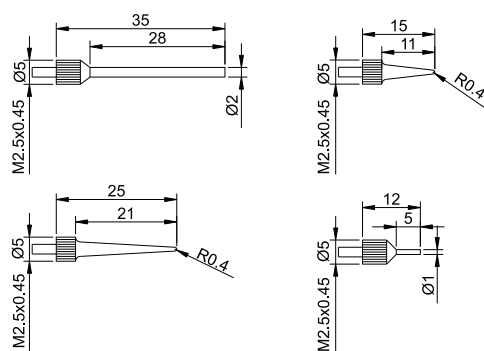
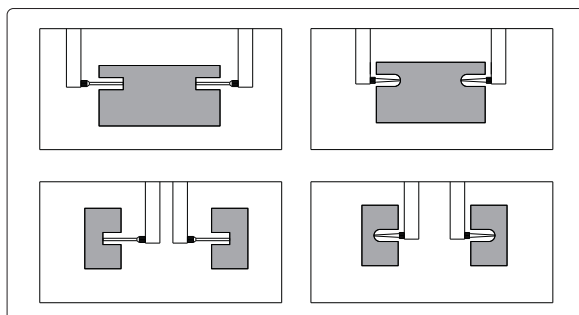

zero setting block for external measurement (included)

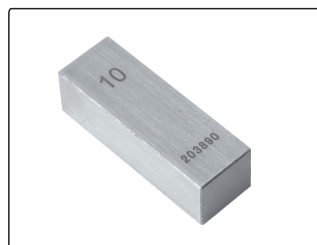

4 pairs of points (included)

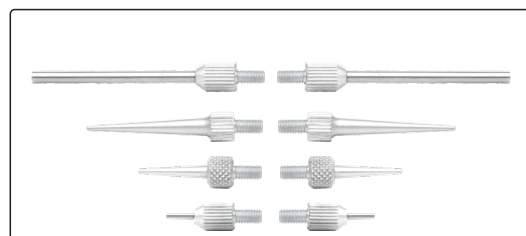

- ◆ Supplied with 4 pairs of points
(Cylindrical needle point: 270-006-16 2pc,
Cylindrical needle point: 270-006-04 2pc,
Conical needle point: 270-006-21 2pc,
Conical needle point: 270-006-23 2pc)
- ◆ Zero setting block for external measurement
- ◆ Resolution: 0.01mm/0.0005"
- ◆ Buttons: on/off, set, mm/inch, preset (+, -)
- ◆ Automatic power off, move the digital unit to turn on power
- ◆ Data output
- ◆ Made of stainless steel

| Code | Range | Accuracy |
|------------|---------------|----------|
| 149-012-21 | 0-300mm/0-12" | ±0.04mm |