

VERNIER DEPTH CALIPER

SERIES 175

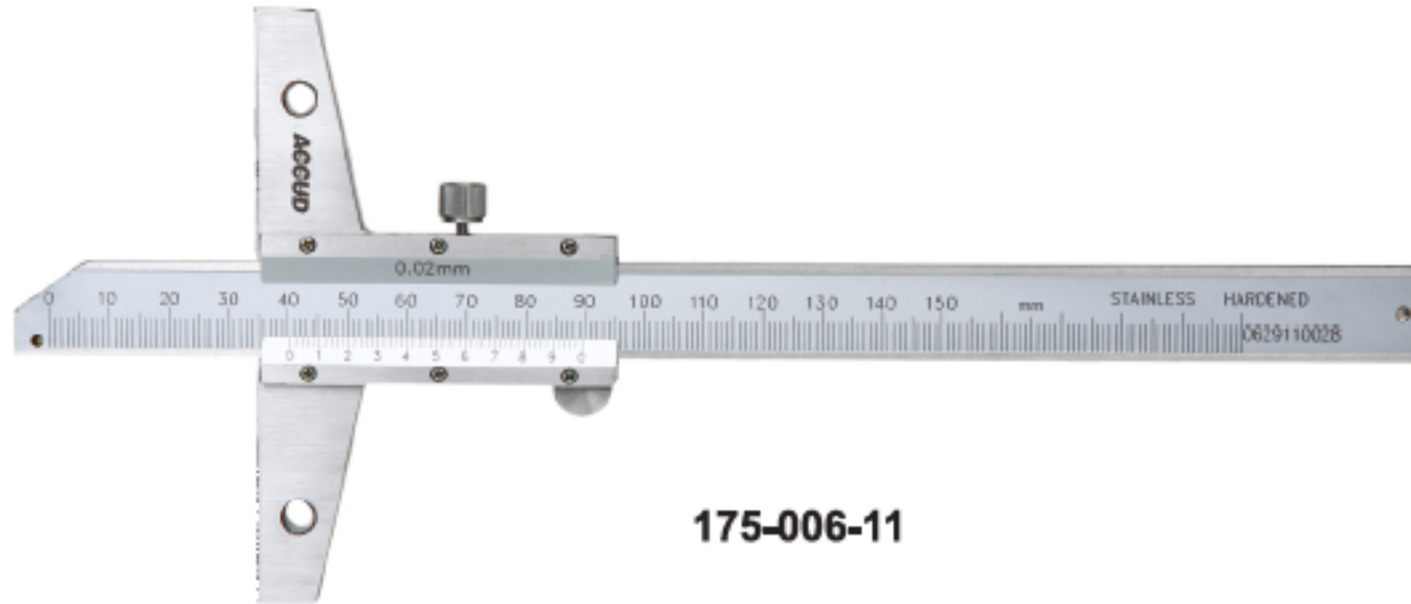

175-006-11

- ◆ Made of stainless steel
- ◆ Satin chrome plating finish on reading surface
- ◆ Optional accessory: extension base

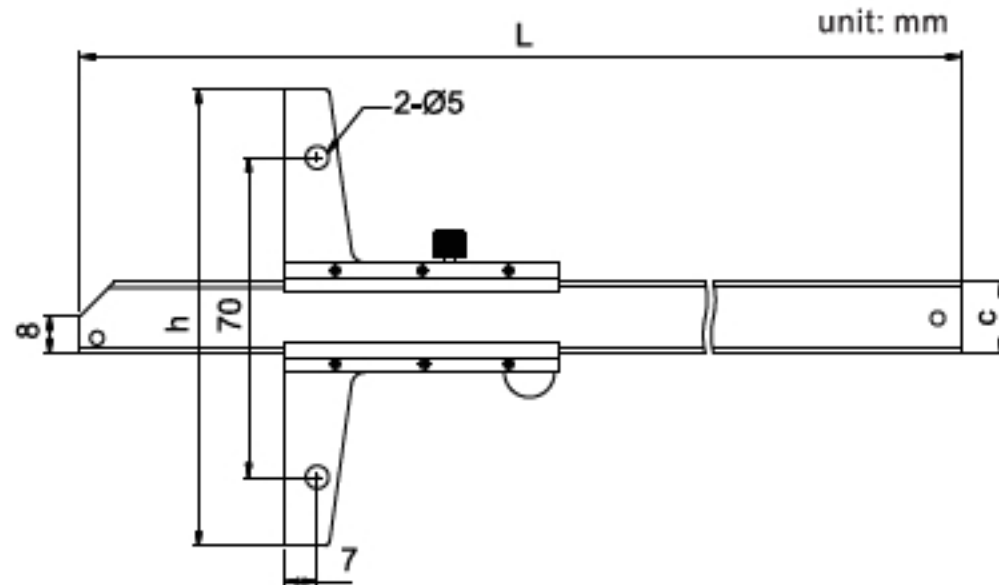

Code	Range	Graduation	Accuracy	c	h	L
175-006-11	0-150mm	0.02mm	±0.03mm	16	100	240
175-008-11	0-200mm	0.02mm	±0.03mm	16	100	290
175-012-11	0-300mm	0.02mm	±0.04mm	16	100	390
175-024-11	0-600mm	0.02mm	±0.05mm	16	150	704
175-040-11	0-1000mm	0.02mm	±0.07mm	18	200	1124
175-006-13	0-150mm	0.05mm	±0.05mm	16	100	240
175-008-13	0-200mm	0.05mm	±0.05mm	16	100	290
175-012-13	0-300mm	0.05mm	±0.08mm	16	100	390
175-024-13	0-600mm	0.05mm	±0.10mm	16	150	704
175-040-13	0-1000mm	0.05mm	±0.15mm	18	200	1124