

# DIAL TEST INDICATOR

## SERIES 261



261-030-51

- ◆ Jeweled bearing
- ◆ Carbide contact point
- ◆ Two measuring directions
- ◆ Anti magnetic body
- ◆ Supplied with two clamps: 5/32" DIA and 3/8" DIA

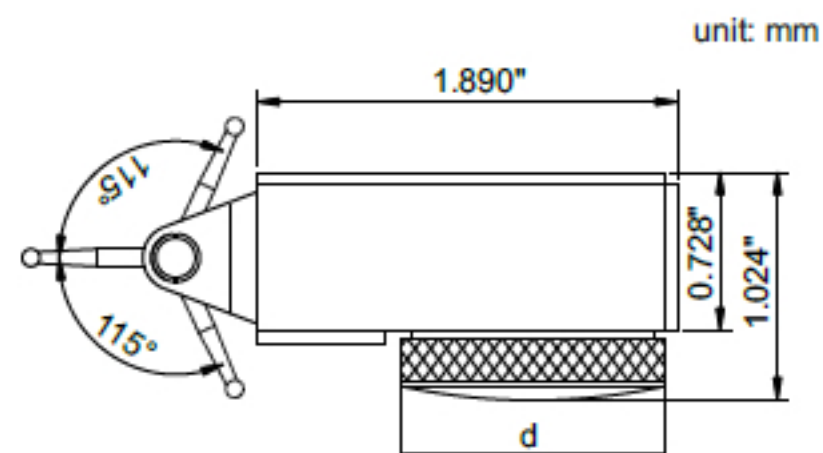

### Clamp

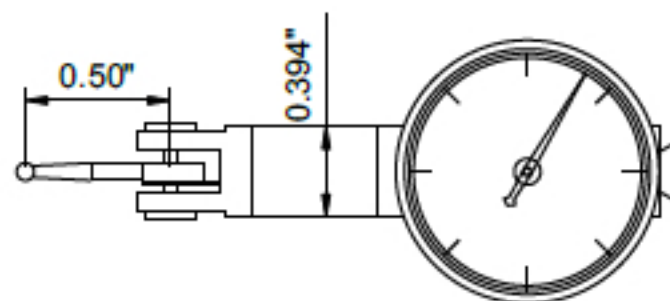
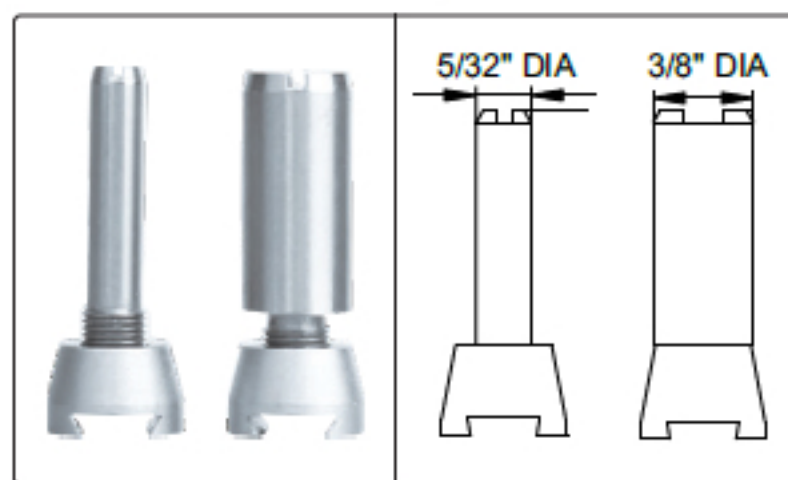

Code	Range	Graduation	Accuracy	Dial reading	d
261-030-51	0.03"	0.0005"	±0.0005"	0-15-0	1.181"DIA
261-030-52	0.03"	0.0005"	±0.0005"	0-15-0	1.457"DIA