

DIGITAL BLADE MICROMETER

SERIES 316

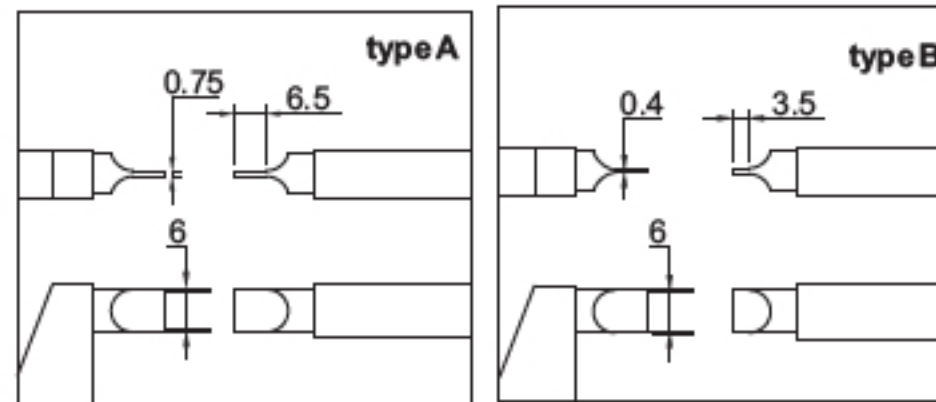

316-001-01

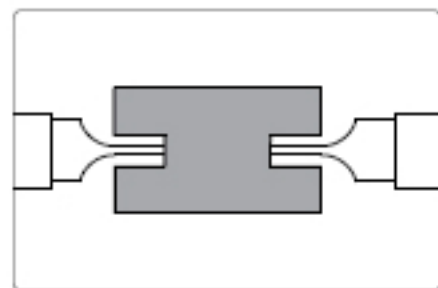
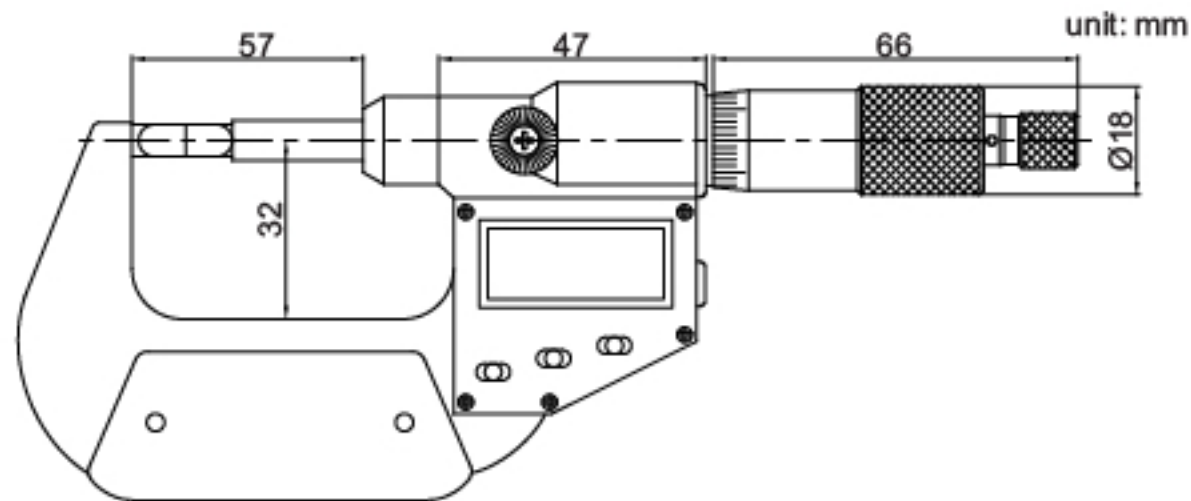

- ◆ Measure the groove diameter of shafts and keyways
- ◆ Resolution 0.001mm/0.00005"
- ◆ Non-rotating spindle
- ◆ Button: on/off, set, mm/inch, ABS/INC, data output
- ◆ Data output
- ◆ Automatic power off
- ◆ Ratchet stop
- ◆ Supplied with setting standards (except 0-25mm/0-1")

Code	Range	Accuracy	Type
316-001-01	0-25mm/0-1"	±4μm	A
316-002-01	25-50mm/1-2"	±4μm	A
316-003-01	50-75mm/2-3"	±5μm	A
316-004-01	75-100mm/3-4"	±5μm	A
316-001-02	0-25mm/0-1"	±4μm	B
316-002-02	25-50mm/1-2"	±4μm	B