

DIGITAL BLADE MICROMETER

SERIES 316

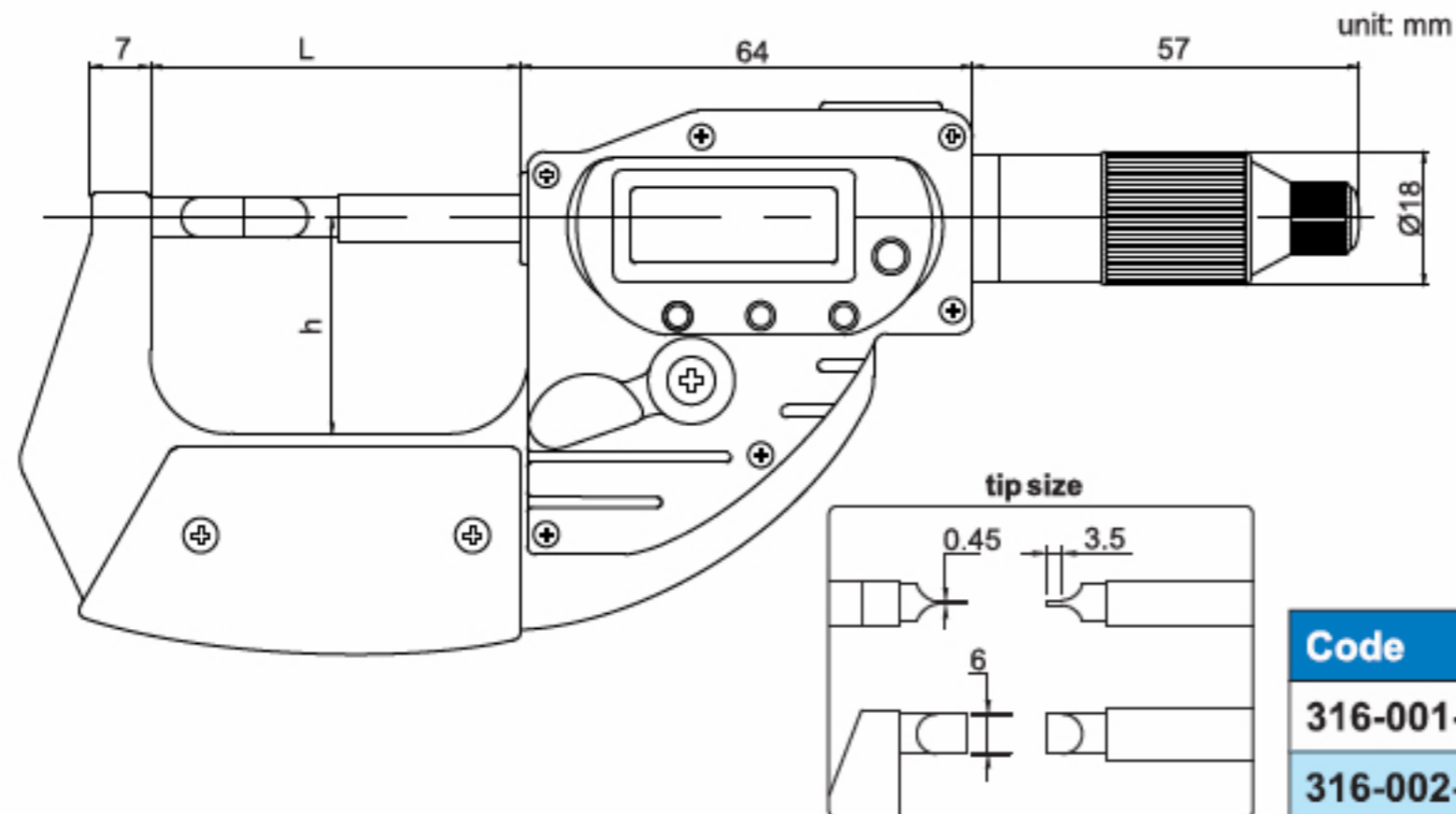

316-001-03



- ◆ Measure the groove diameter of shafts and keyways
- ◆ Quick measurement with lever
- ◆ Resolution: 0.001mm/0.00005"
- ◆ IP65 protection level
- ◆ Button: on/off, mm/inch, origin, ABS/zero
- ◆ Automatic power off
- ◆ Data output
- ◆ Carbide measuring faces
- ◆ Setting standards are included (except 316-001-03)

Code	Range	Accuracy	h	L
316-001-03	0-25mm/0-1"	3µm	31	55
316-002-03	25-50mm/1-2"	3µm	44	80