

SERIES 327

POINT MICROMETER

- ◆ Measure the thickness of drills, small grooves and keyways
- ◆ Graduation: 0.01mm
- ◆ Ratchet stop
- ◆ Carbide measuring faces
- ◆ Setting standards are included (except 0-25mm)



327-001-03

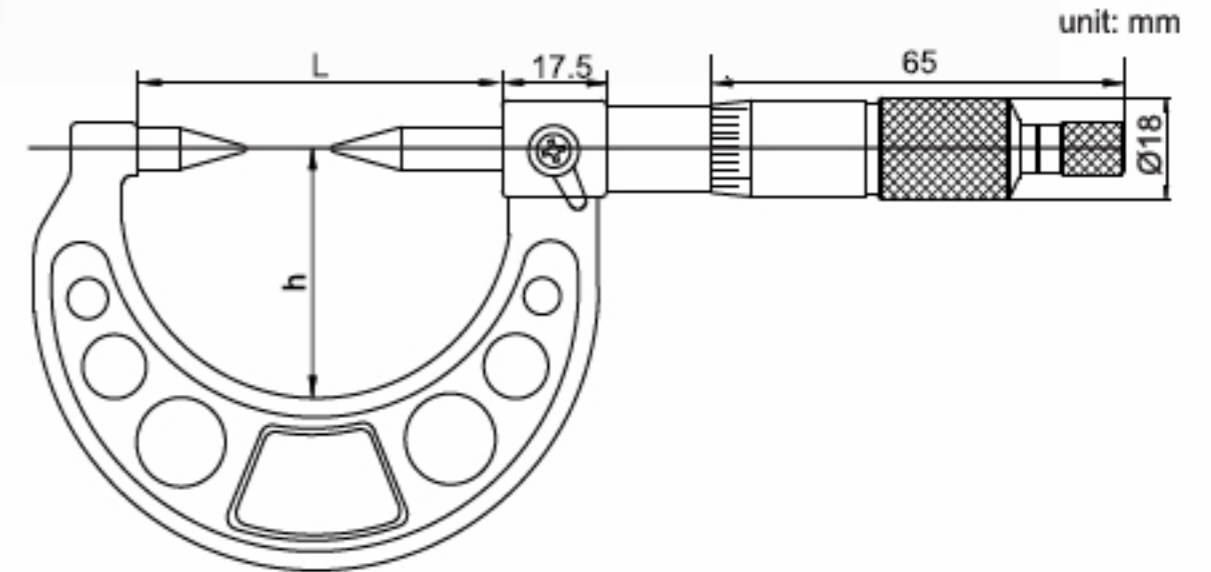

unit: mm

Code	Range	Anvil	Accuracy	h	L
327-001-03	0-25mm	A	4μm	39	58
327-002-03	25-50mm	A	4μm	53	83
327-003-03	50-75mm	A	5μm	65	109
327-004-03	75-100mm	A	5μm	76	133
327-001-04	0-25mm	B	4μm	39	58
327-002-04	25-50mm	B	4μm	53	83
327-003-04	50-75mm	B	5μm	65	109
327-004-04	75-100mm	B	5μm	76	133

