

# SERIES 328

# SPLINE MICROMETER

- ◆ Measure grooves and sharped parts
- ◆ Graduation: 0.01mm
- ◆ Carbide measuring faces
- ◆ Ratchet stop
- ◆ Setting standards are included  
(except 0-25mm)



328-001-03

unit: mm

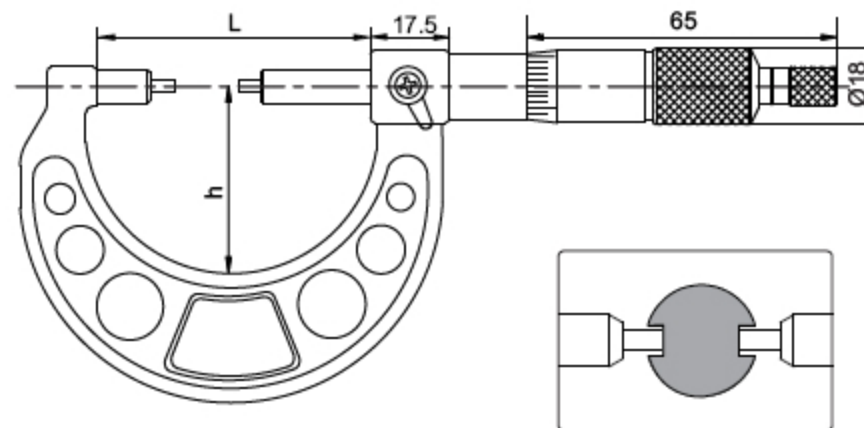

Code	Range	Accuracy	Anvil	h	L
328-001-04	0-25mm	4μm	A	32	57
328-001-03	0-25mm	4μm	B	32	57
328-002-03	25-50mm	4μm	B	44.5	82
328-003-03	50-75mm	5μm	B	57	107
328-004-03	75-100mm	5μm	B	69.5	132.6
328-005-03	100-125mm	6μm	B	82	158
328-006-03	125-150mm	6μm	B	94.5	183.4
328-007-03	150-175mm	7μm	B	107	208.8

NEW  
NEW  
NEW

