

SERIES 330

JAW TYPE MICROMETER

- ◆ Graduation :0.01mm
- ◆ Non-rotating spindle,paintedframe,
- ◆ Ratchet stop
- ◆ Supplied with setting standards
(except 330-001-01)

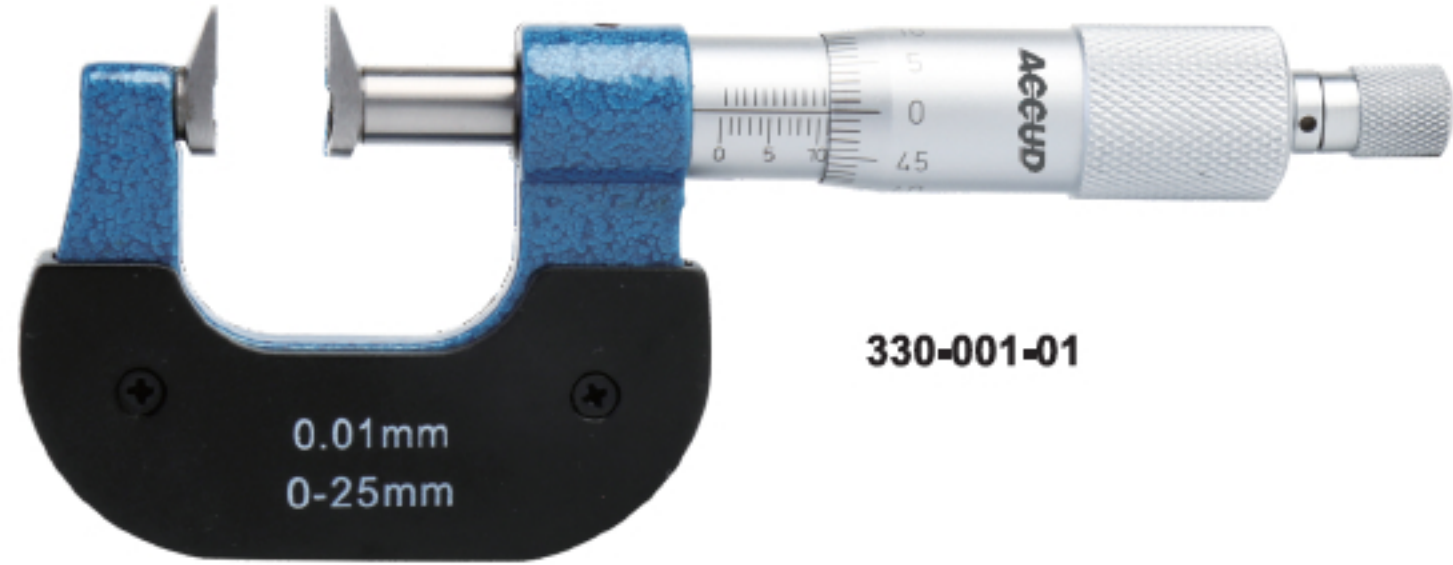

330-001-01

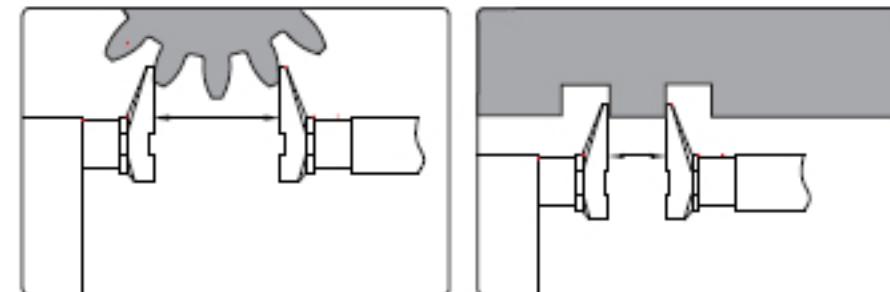
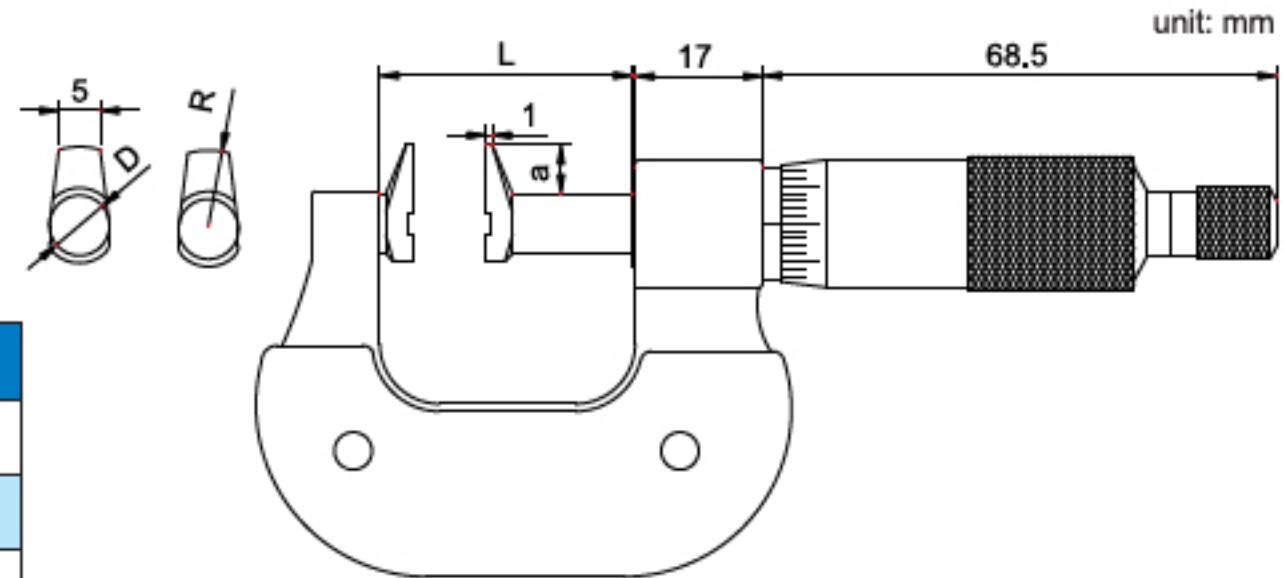

Code	Range	Accuracy	L	a	R	D
330-001-01	0-25mm	4μm	34	6	10	8
330-002-01	25-50mm	4μm	59	6	10	8
330-003-01	50-75mm	5μm	85	6	10	8
330-004-01	75-100mm	5μm	110	6	10	8
330-005-01	100-125mm	6μm	138	9	15	12
330-006-01	125-150mm	6μm	163	9	15	12
330-007-01	150-175mm	7μm	188	9	15	12
330-008-01	175-200mm	7μm	214	9	15	12