

SERIES 332

DIGITAL NON ROTATING SPINDLE DISK MICROMETER

- ◆ Measure root tangent length of gear
- ◆ Resolution 0.001mm/0.00005"
- ◆ Non-rotating spindle
- ◆ Button: on/off, set, mm/inch, ABS/INC, data output
- ◆ Data output
- ◆ Automatic power off
- ◆ Ratchet stop
- ◆ Supplied with setting standards (except 332-001-01)



332-001-01

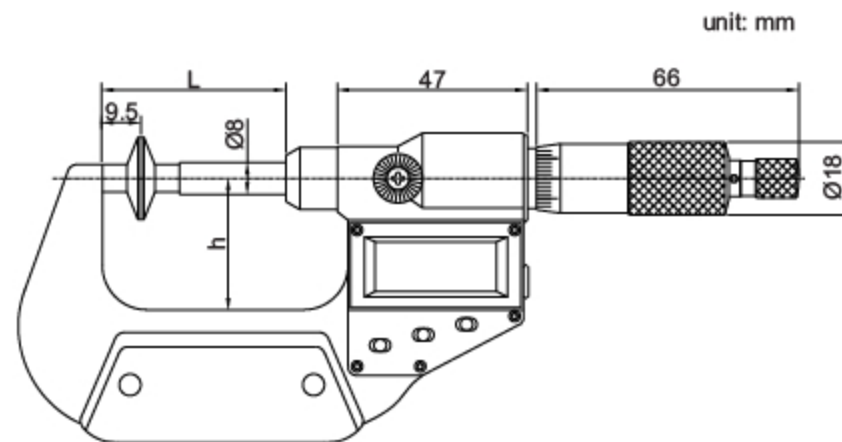

Code	Range	Accuracy	L	h
332-001-01	0-25mm/0-1"	±4μm	43	32
332-002-01	25-50mm/1-2"	±4μm	68	44.5
332-003-01	50-75mm/2-3"	±5μm	93	57
332-004-01	75-100mm/3-4"	±5μm	118.5	70

