

SERIES 334

DIGITAL V-ANVIL MICROMETER

- ◆ Measure the outside diameter of cutting tools (such as taps, reamers, end mills) with 3 flutes
- ◆ Resolution: 0.001mm/0.00005"
- ◆ IP54 protection level
- ◆ Button: on/off, set, mm/inch, ABS/INC, data output
- ◆ Data output
- ◆ Automatic power off
- ◆ Ratchet stop
- ◆ Carbide measuring faces
- ◆ Supplied with setting standards



334-015-01

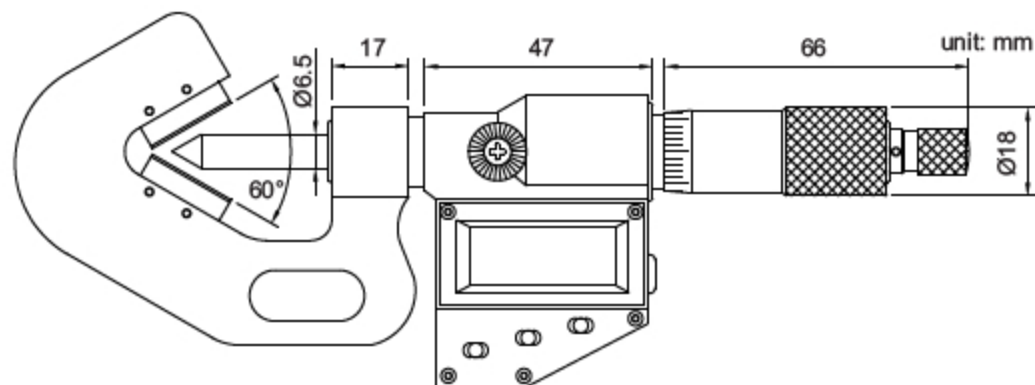

Code	Range	Accuracy	Flutes
334-015-01	1-15mm/0.04-0.6"	$\pm 4\mu\text{m}$	3
334-020-01	5-20mm/0.2-0.8"	$\pm 4\mu\text{m}$	3
334-035-01	20-35mm/0.8-1.4"	$\pm 5\mu\text{m}$	3
334-050-01	35-50mm/1.4-2.0"	$\pm 5\mu\text{m}$	3