

SERIES 334

V-ANVIL MICROMETER

- ◆ Measure the outside diameter of cutting tools (such as taps, reamers, end mills) with 3 or 5 flutes
- ◆ Graduation 0.01mm
- ◆ Ratchet stop
- ◆ Carbide measuring faces
- ◆ Supplied with setting standards



334-006-01

Code	Range	Accuracy	Flutes
334-006-01	1-15mm	4μm	3
334-008-01	5-20mm	4μm	3
334-012-01	20-35mm	5μm	3
334-019-01	35-50mm	5μm	3
334-024-01	50-65mm	6μm	3
334-032-01	65-80mm	6μm	3
334-036-01	80-95mm	7μm	3
334-025-05	5-25mm	4μm	5
334-045-05	25-45mm	5μm	5
334-065-05	45-65mm	6μm	5
334-085-05	65-85mm	7μm	5

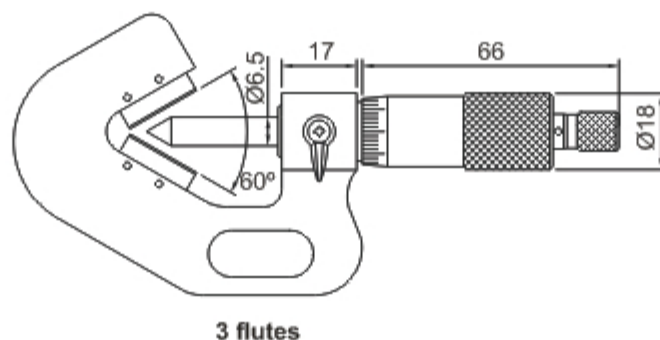

3 flutes

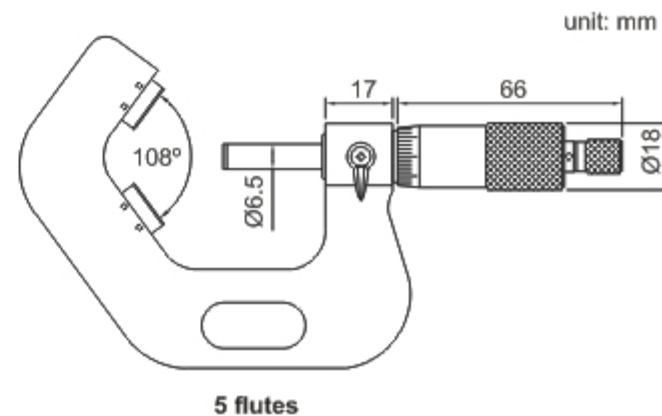

5 flutes