

SERIES 350

DIGITAL SHEET METAL MICROMETER

- ◆ Deep frame suitable for sheet metal, paper and plastic
- ◆ Resolution: 0.001mm/0.00005"
- ◆ IP65 protection level
- ◆ Button: on/off, mm/inch, set, zero, ABS/INC, date output
- ◆ Date output
- ◆ Automatic power off
- ◆ Carbide measuring faces, ratchet stop



350-001-11

unit: mm

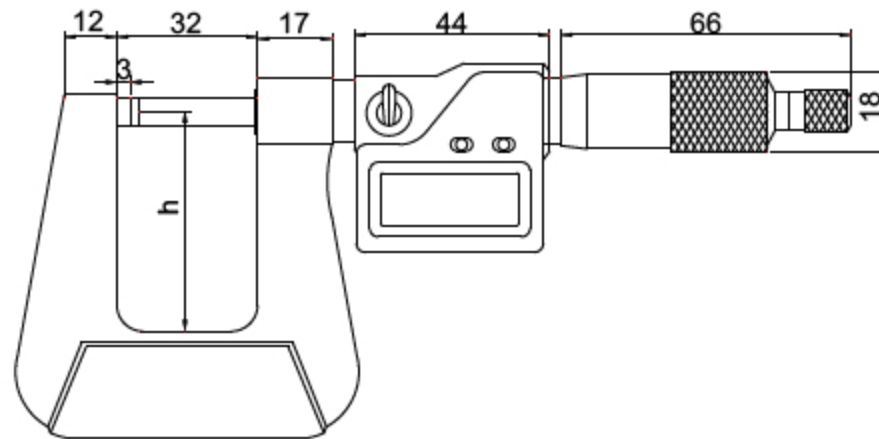

Code	Range	Accuracy	Type	h
350-001-11	0-25mm/0-1"	±3μm	A	50
350-001-12	0-25mm/0-1"	±5μm	A	100
350-001-13	0-25mm/0-1"	±7μm	A	150
350-001-21	0-25mm/0-1"	±3μm	B	50
350-001-22	0-25mm/0-1"	±5μm	B	100
350-001-23	0-25mm/0-1"	±7μm	B	150
350-001-31	0-25mm/0-1"	±3μm	C	50
350-001-32	0-25mm/0-1"	±5μm	C	100
350-001-33	0-25mm/0-1"	±7μm	C	150

