

MICROMETER HEAD

SERIES 371

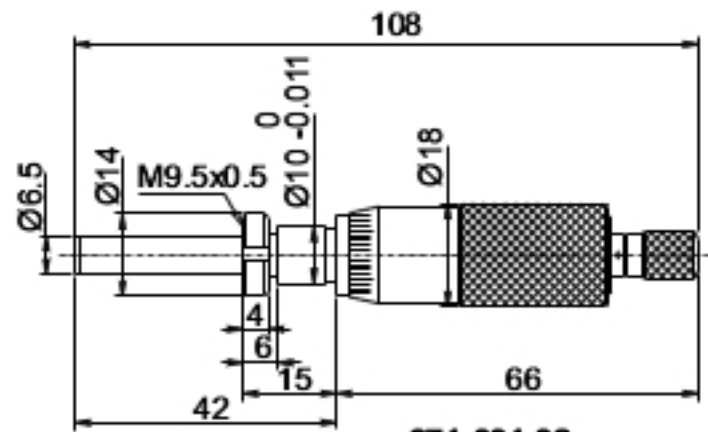

371-001-02



371-001-02

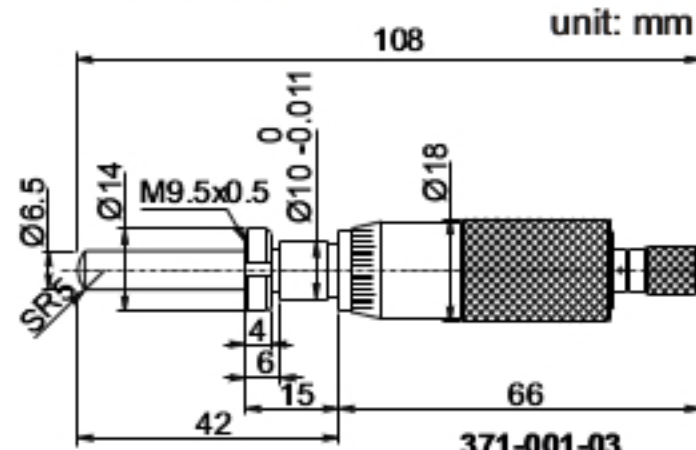

371-001-03

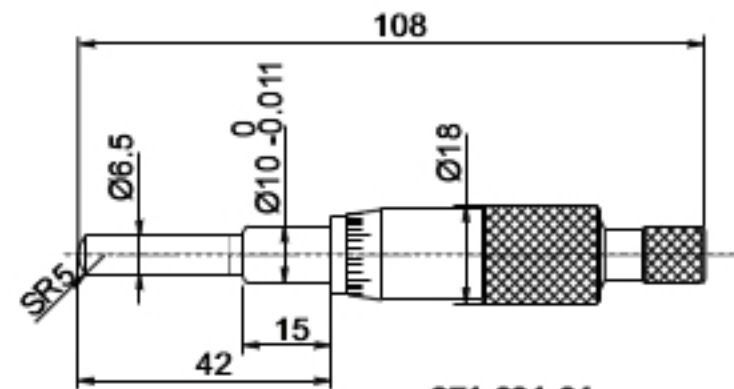

371-001-04

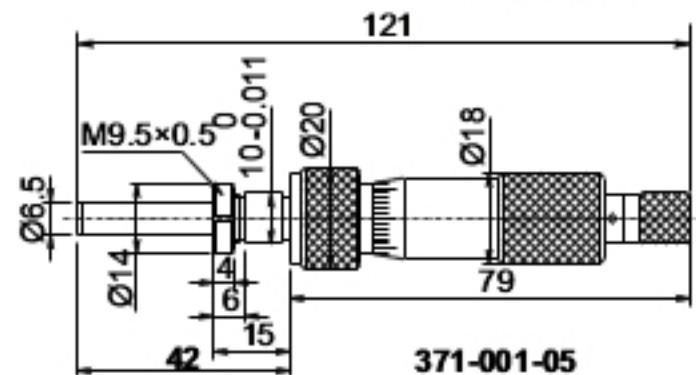

371-001-05

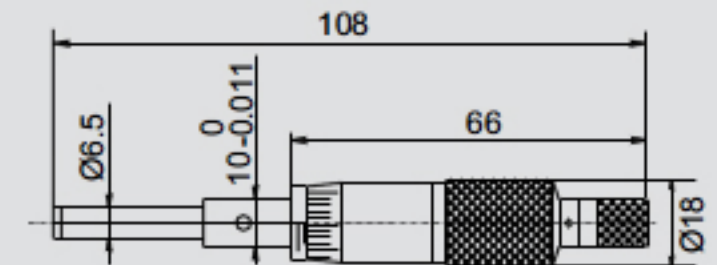

371-001-11

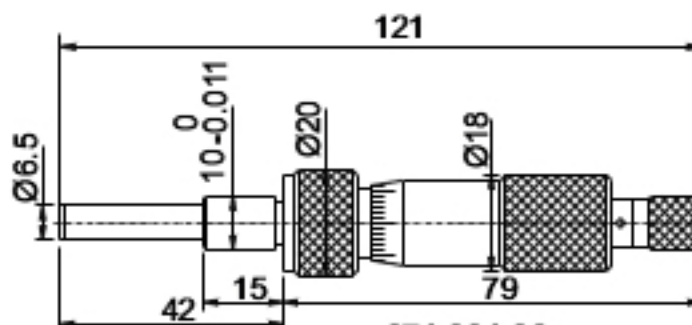

371-001-06

- ◆ Graduation: 0.01mm
- ◆ Accuracy: 0.003mm
- ◆ Carbide measuring faces
- ◆ Ratchet stop

Code	Range	Stem	Spindle tip	Remark
371-001-02	0-25mm	with clamp nut	flat (carbide)	
371-001-03	0-25mm	with clamp nut	spherical (SR5)	
371-001-04	0-25mm	plain	spherical (SR5)	
371-001-05	0-25mm	with clamp nut	flat (carbide)	with spindle lock
371-001-06	0-25mm	plain	flat (carbide)	with spindle lock
371-001-11	0-25mm	plain	flat (carbide)	