

◆ Graduation 0.01mm

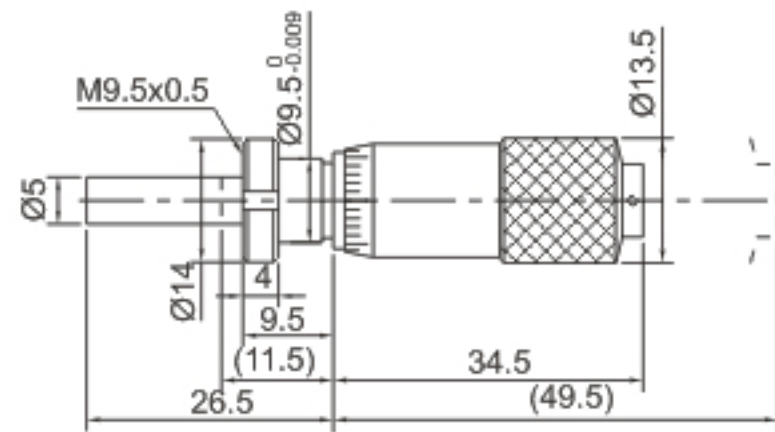

373-001-01

unit: mm



373-001-01

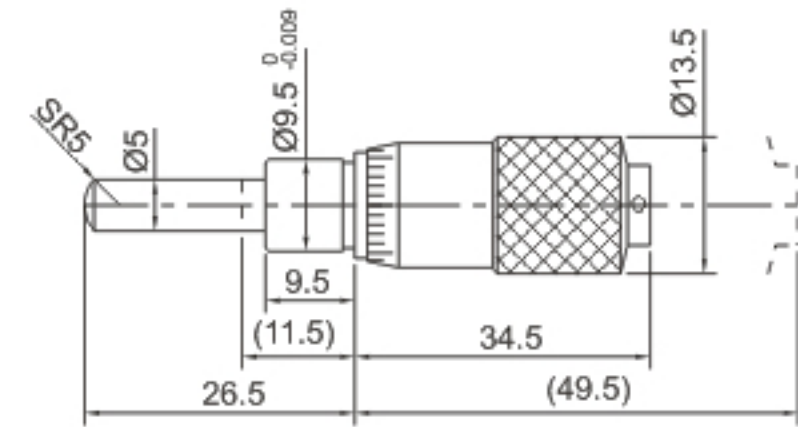

373-001-04

Code	Range	Accuracy	Stem	Spindle tip
373-001-01	0-15mm	3µm	with clamp nut	flat (carbide)
373-001-02	0-15mm	3µm	plain	flat (carbide)
373-001-03	0-15mm	3µm	with clamp nut	spherical (SR5)
373-001-04	0-15mm	3µm	plain	spherical (SR5)