

# SERIES 380

# DIGITAL CYLINDRICAL ANVIL TUBE MICROMETER

- ◆ Measure wall thickness of tubes
- ◆ Resolution 0.001mm/0.00005"
- ◆ IP54 protection level
- ◆ Button: on/off, set, mm/inch, ABS/INC, data output
- ◆ Data output
- ◆ Automatic power off
- ◆ Ratchet stop
- ◆ Carbide spindle tip



380-001-04

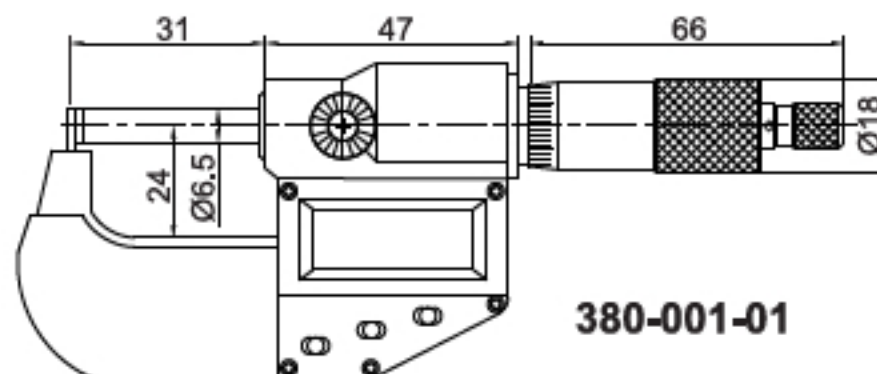

unit: mm

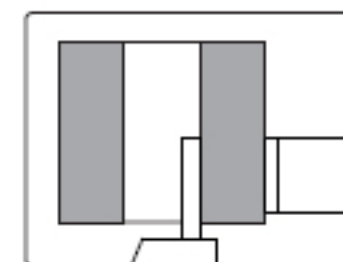

Code	Range	Accuracy	Type
380-001-01	0-25mm/0-1"	±6μm	A
380-001-02	0-25mm/0-1"	±6μm	B
380-001-03	0-25mm/0-1"	±6μm	C
380-001-04	0-25mm/0-1"	±6μm	D

