

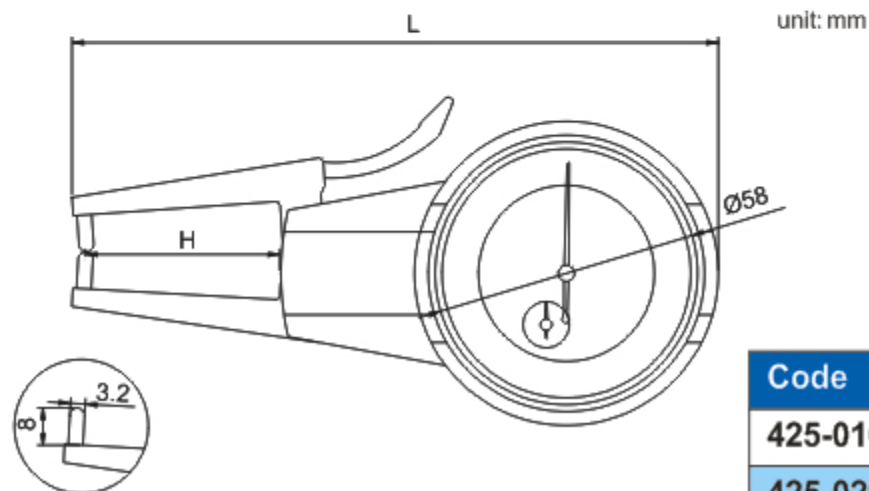

425-010-11

- ◆ Measure the external dimension



Code	Range	Graduation	Accuracy	L	H
425-010-11	0-10mm	0.01mm	±0.03mm	140mm	41mm
425-020-11	0-20mm	0.01mm	±0.03mm	192mm	92mm