

SERIES 431

DIAL SNAP GAUGE

- ◆ For quick Go/No-Go judgment of diameter of cylinders and shafts
- ◆ Anvil retracting stroke: 3mm
- ◆ Measuring force: 6-9N
- ◆ Carbide measuring faces
- ◆ Front edges of anvils are chamfered for easy workpiece insertion
- ◆ Optional indicators:
 - dial indicator, range 10mm, graduation 0.01mm
(code **222-010-11**)
 - digital indicator, range 12.7mm/0.5", resolution 0.001mm/0.00005"
(code **211-010-03**)
 - digital indicator, range 12.7mm/0.5", resolution 0.01mm/0.0005"
(code **211-010-13**)

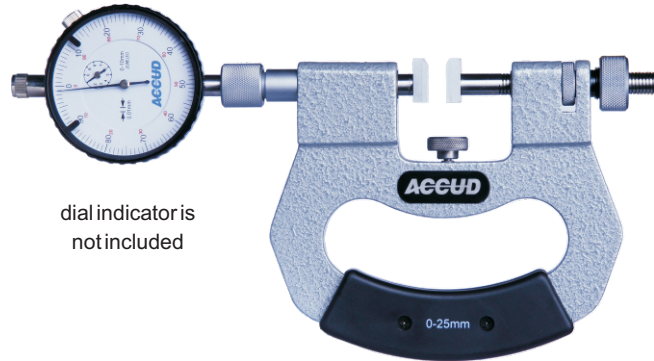

dial indicator is not included

431-025-11

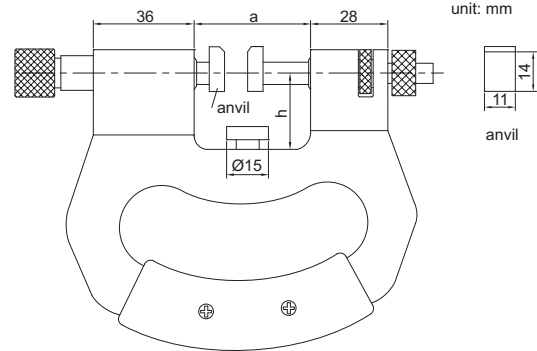

optional indicators

Code	Range	a	h
431-025-11	0-25mm	42	20
431-050-11	25-50mm	69	32.5
431-075-11	50-75mm	94	45
431-100-11	75-100mm	119	57.5
431-125-11	100-125mm	144	70
431-150-11	125-150mm	169	82.5
431-175-11	150-175mm	194	95
431-200-11	175-200mm	219	107
431-225-11	200-225mm	244	120
431-250-11	225-250mm	269	132
431-275-11	250-275mm	294	145
431-300-11	275-300mm	319	157



222-010-11

211-010-03

211-010-13