

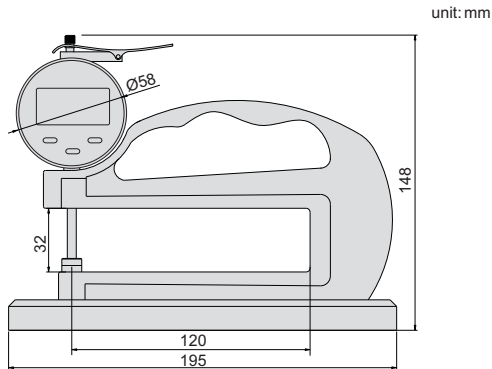

- ◆ Ceramic spindle tip and anvil
- ◆ Buttons: on/off, zero, mm/inch, ABS
- ◆ Automatic power off
- ◆ Data output
- ◆ With metal base



Code	Range	Graduation	Accuracy
460-010-11B	0-10mm/0-0.4"	0.01mm/0.0005"	±0.02mm