

SERIES 632

V-BLOCK SET

- ◆ Two V blocks per set
- ◆ Made of hardened tool steel

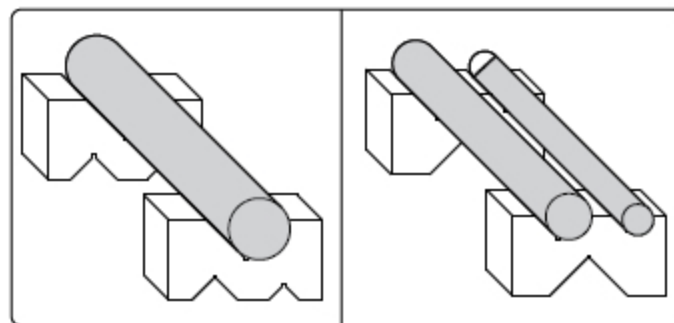
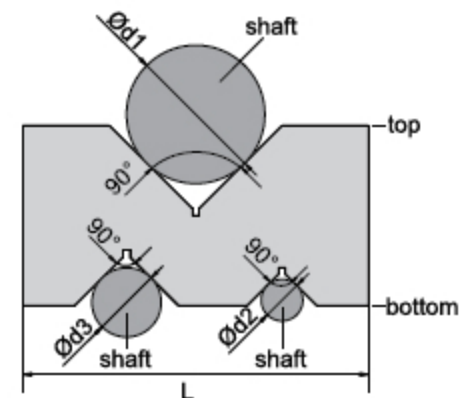
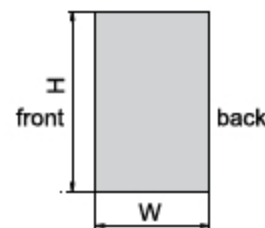
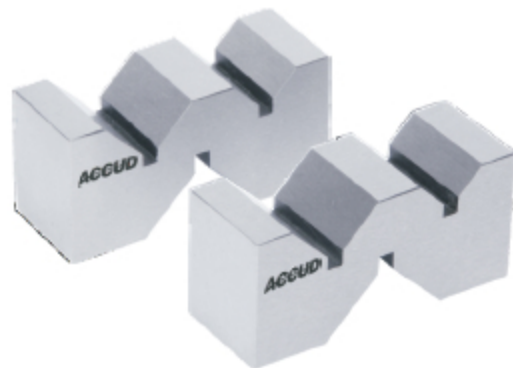

Code	Size (LxWxH)	Range of shafts(Ød1)	Range of shafts(Ød2)	Range of shafts(Ød3)	Parallelism of V grooves to top and bottom sides	Squareness of V grooves to front and back sides	Height difference of a matched pair
632-002-01	50x19x24	3-32	3-16	3-22	5µm	5µm	5µm
632-003-01	75x24x35	3-50	3-20	3-32	5µm	5µm	5µm
632-004-01	100x33x52	3-68	3-26	3-40	5µm	5µm	5µm
632-006-01	150x50x80	6-100	5-40	5-60	5µm	5µm	5µm