

MAGNETIC V-BLOCK

SERIES 634

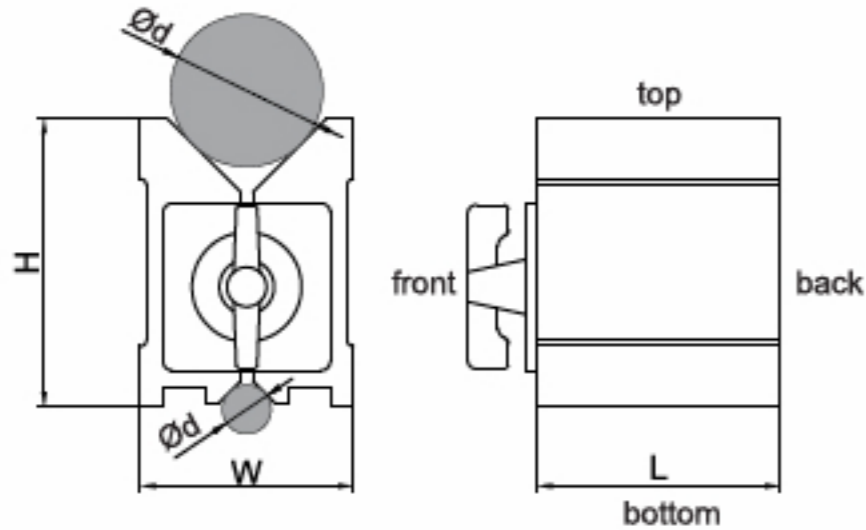

634-067-01

- ◆ Hold cylindrical workpiece for inspection and machining
- ◆ Top groove for large shafts
- ◆ Bottom grooves for small shafts

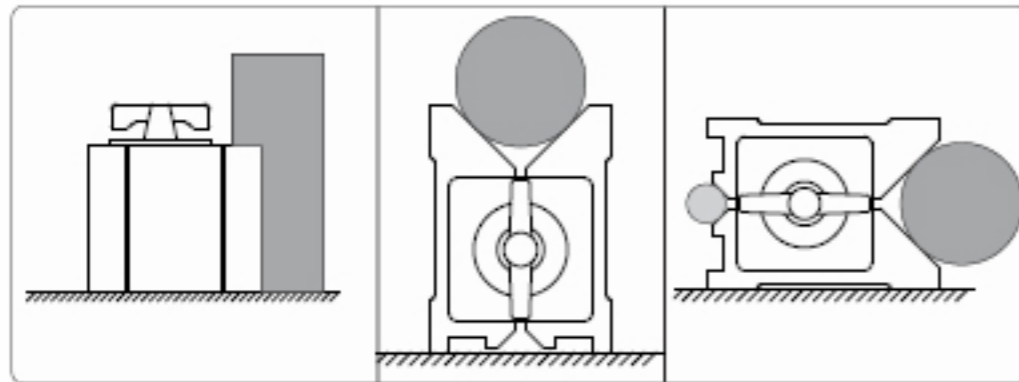

Code	Size(LxWxH)	For shaft range ($\varnothing d$)	Magnetic force	V-grooves and back side squareness	Top side and bottom side parallelism
634-067-01	80x70x95mm	6-67mm	64kgf	10 μ m	10 μ m
634-067-02	100x70x95mm	6-67mm	80kgf	10 μ m	10 μ m
634-067-03	120x70x95mm	6-67mm	96kgf	10 μ m	10 μ m