

# MAGNETIC V-BLOCK SET

## SERIES 635

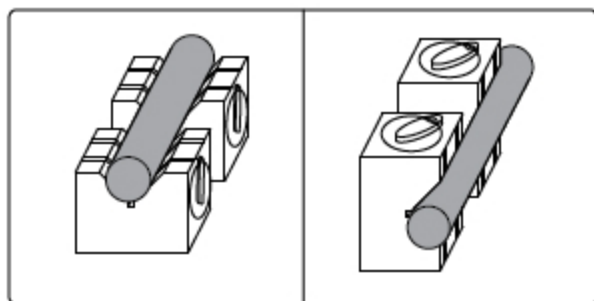
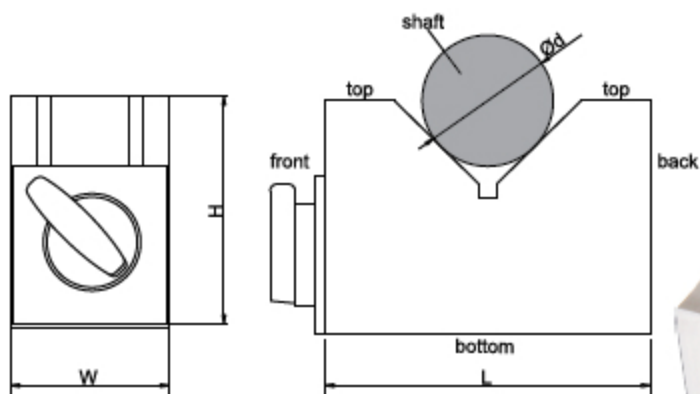

635-150-01

- ◆ Hold cylindrical workpieces for inspection, not suitable for machining due to weak magnetic force
- ◆ Two V-blocks per set

Code	Size(LxWxH)	Range of shafts ( $\varnothing d$ )	Magnetic force	Parallelism of V groove to bottom and back sides	Height difference of a matched pair
635-070-01	70x40x50mm	6-46mm	8kgf	10 $\mu$ m	10 $\mu$ m
635-150-01	150x50x100mm	6-125mm	14kgf	10 $\mu$ m	10 $\mu$ m