

V-BLOCK SET

SERIES 637

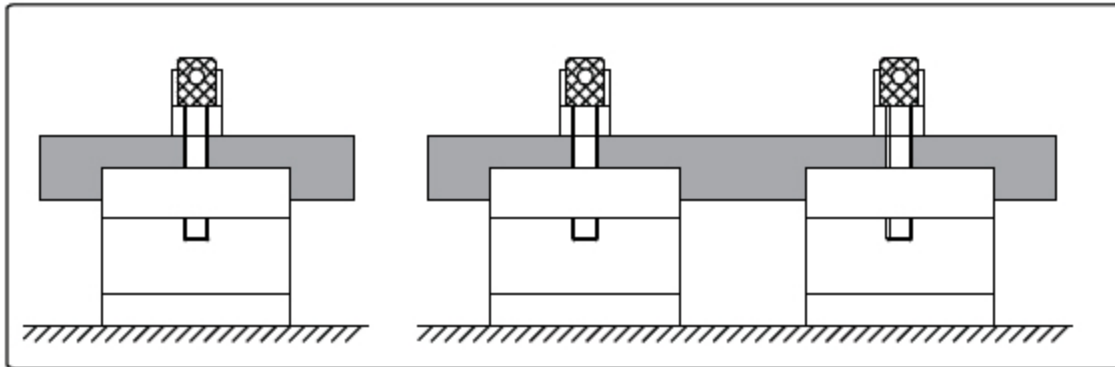
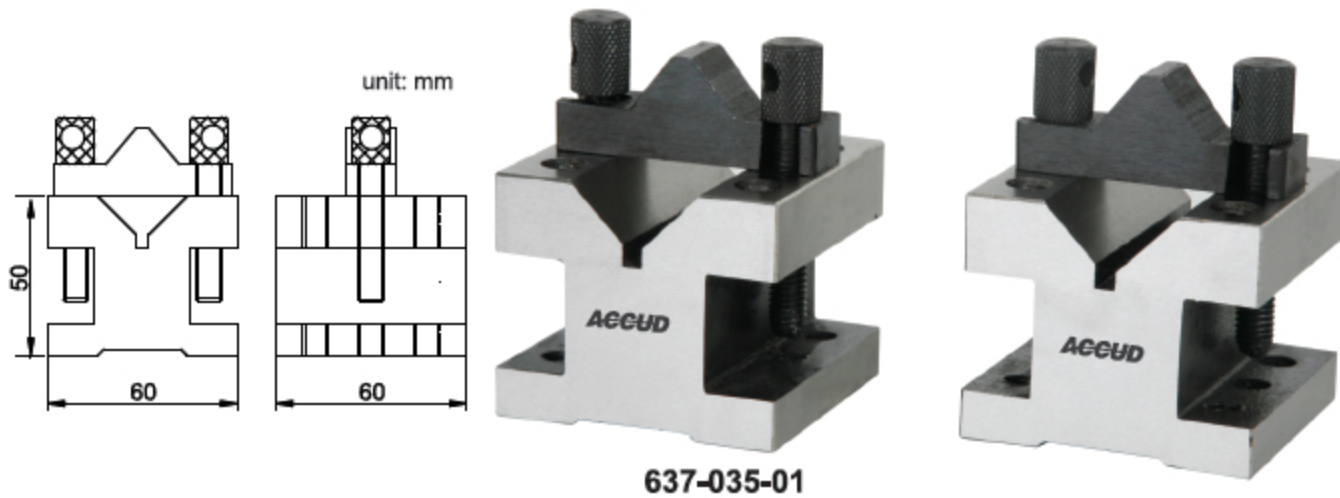

- ◆ Hold cylindrical workpieces for inspection and machining
- ◆ Two V-blocks per set
- ◆ V groove on the top for large shafts

Code	Size(LxWxH)	For shaft range($\varnothing d$)	V grooves to top and bottom sides parallelism	V grooves to front and back sides squareness	Height difference of a matched pair
637-035-01	35x35x30mm	3 - 16mm	5 μ m	5 μ m	5 μ m
637-060-01	60x60x50mm	5 - 34mm	5 μ m	5 μ m	5 μ m
637-105-01	105x105x78mm	8 - 66mm	5 μ m	5 μ m	5 μ m