

- ◆ Calculating card is included
- ◆ Made of stainless steel

calculating card (included)

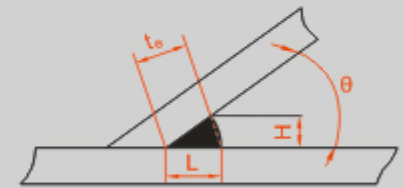
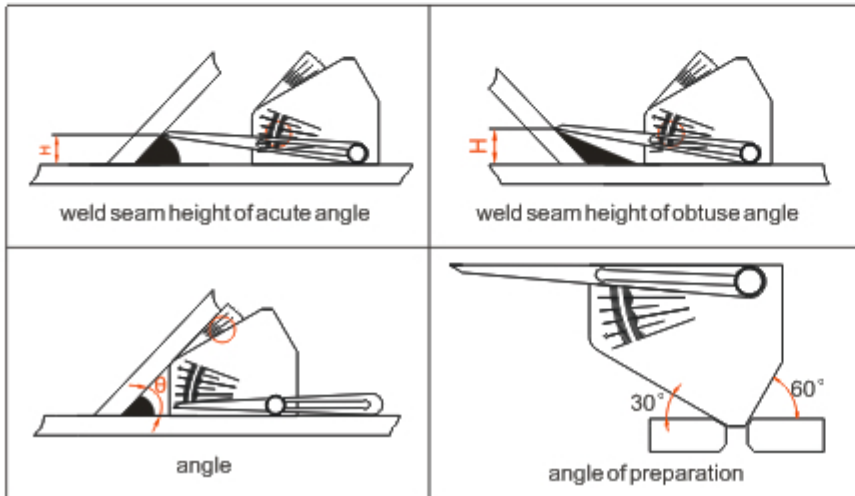
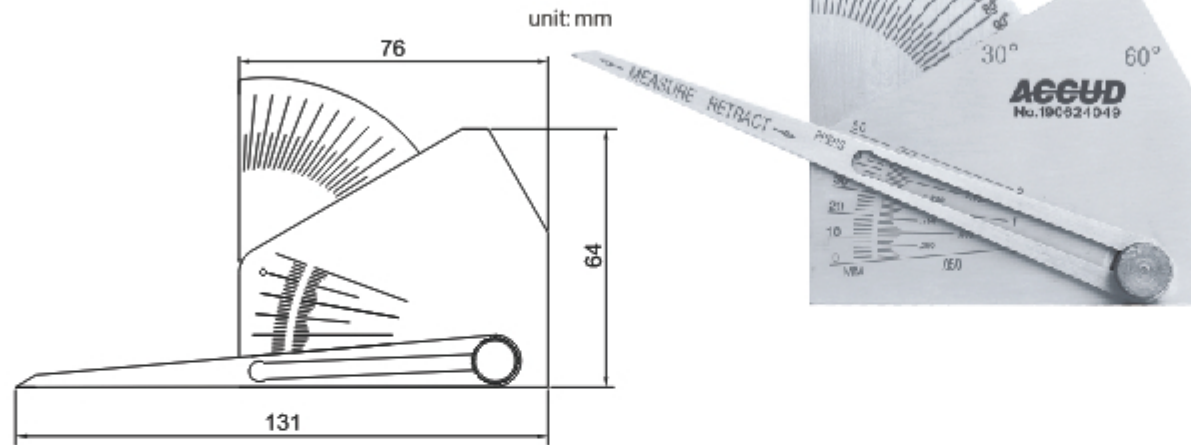
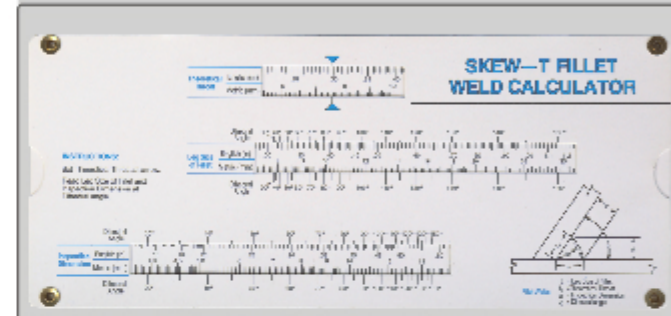

measure weld seam height H and angle θ , calculate theoretical throat size t_e and leg height L according to H and θ .

| Code | Range | Graduation | Accuracy | Measurement |
|------------|---------------|-------------|----------|----------------------|
| 969-050-01 | 0-50mm / 0-2" | 2mm / .050" | ±1mm | weld seam height H |
| | 30° - 90° | 2.5° | ±1° | angle θ |
| | — | — | ±0.5° | 90° angle |