

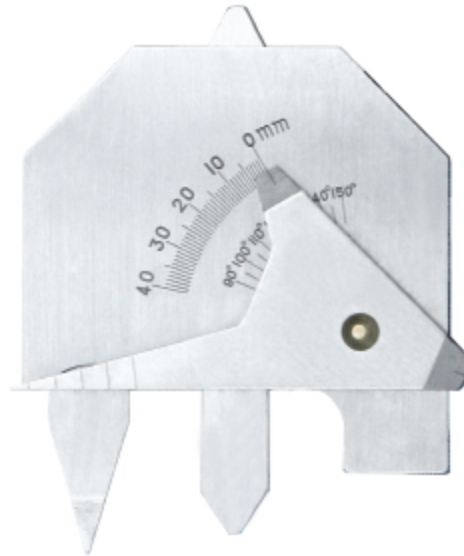

front side



reverse side

◆ Made of stainless steel

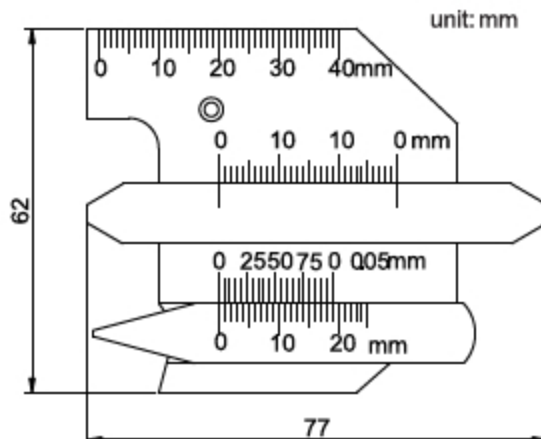

| Code | Application | Range | Graduation | Accuracy |
|------------|------------------------|----------|------------|----------|
| 973-014-01 | measure crown height | 0-10mm | 1mm | ±0.5mm |
| | measure leg height | 0-14mm | 1mm | ±0.5mm |
| | measure undercut depth | 0-5mm | 0.05mm | ±0.05mm |
| | measure throat size | 0-13mm | 1mm | ±0.5mm |
| | measure weld length | 0-40mm | 1mm | ±1mm |
| | measure angle | 90°-150° | 5° | ±1° |
| | measure gap | 0.5-5mm | 1mm | ±0.5mm |
| | measure length | 0-40mm | 1mm | ±0.5mm |