

- ◆ Adjustable scale to compensate pointer wear
- ◆ Made of stainless steel

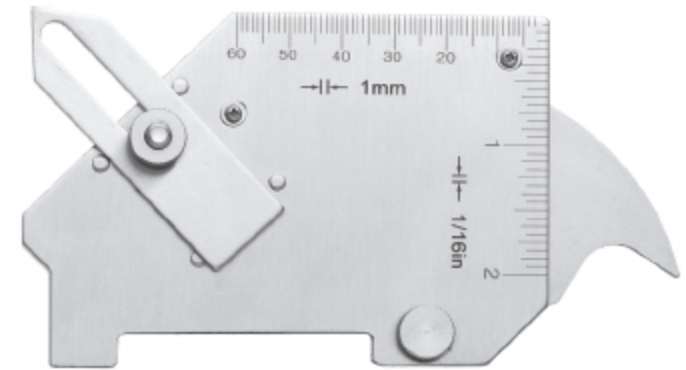

front side



reverse side

Code	Range	Graduation	Accuracy	Application
975-025-01	0-25mm (0-1")	1mm (1/16")	±0.5mm	measure crown height
	0-25mm (0-1")	1mm (1/16")	±0.5mm	measure fillet weld leg height
	0-25mm (0-1")	1mm (1/16")	±0.5mm	measure misalignment
	0-2mm (0-1/8")	1mm (1/16")	±0.5mm	measure undercut depth
	0-20mm (0-3/4")	1mm (1/16")	±0.5mm	measure fillet weld throat size
	0-60°	5°	±1°	measure angle of preparation
	0-60mm (0-2")	1mm (1/16")	±0.5mm	measure length
	—	—	±1°	measure 45° angle

