

SERIES 325

OUTSIDE MICROMETER WITH INTERCHANGEABLE ANVILS

- ◆ Graduation: .0001" (within 12")
.001" (over 12")
- ◆ Ratchet stop
- ◆ Carbide measuring faces
- ◆ Supplied with setting standards



325-006-E01

Setting standards (included)



interchangeable anvils (included)

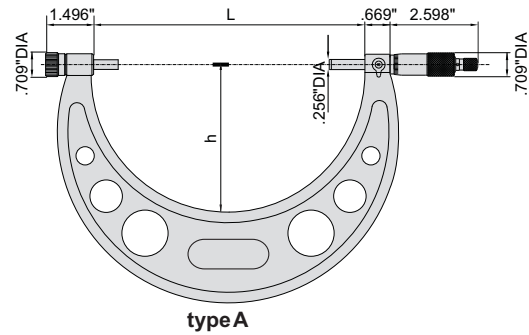
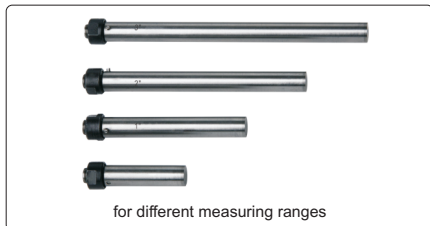

type A

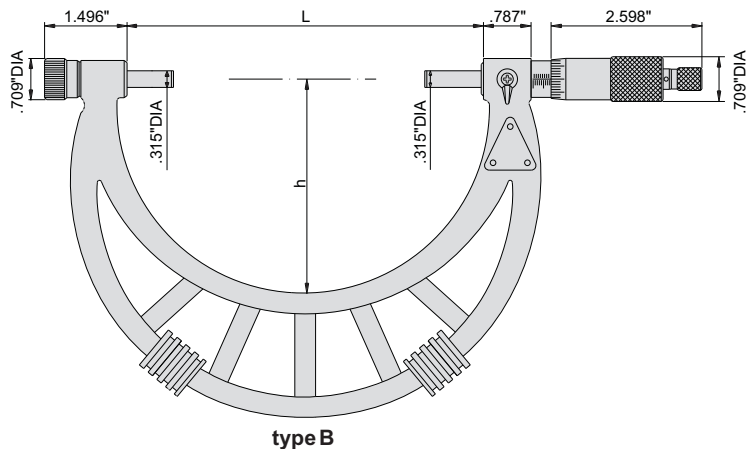

type B

Code	Range	Type	Accuracy	L	h	Setting standards (included)
325-002-E01	0-2"	A	.00016"	2.283"	1.378"	1"
325-004-E01	0-4"	A	.00020"	4.252"	2.244"	1", 2", 3"
325-006-E01	0-6"	A	.00024"	6.220"	3.228"	1", 2", 3", 4", 5"
325-008-E01	4-8"	A	.00028"	8.189"	4.488"	4", 5", 6", 7"
325-012-E01	6-12"	A	.00035"	12.126"	6.496"	6", 7", 8", 9", 10", 11"
325-016-E02	12-16"	B	.00043"	16.102"	8.819"	13", 15"
325-020-E02	16-20"	B	.00051"	20.039"	10.827"	17", 19"
325-024-E02	20-24"	B	.00055"	23.976"	12.638"	21", 23"
325-028-E02	24-28"	B	.00063"	27.913"	14.606"	25", 27"
325-032-E02	28-32"	B	.00071"	31.850"	16.772"	29", 31"
325-036-E02	32-36"	B	.00079"	35.787"	18.740"	33", 35"
325-040-E02	36-40"	B	.00087"	39.724"	22.677"	37", 39"

